



**MIX SERIES**

**USER'S MANUAL**

**MIX SERIES MIXER**





# 9

## GUARANTEE

---

**T.MIX** guarantees the normal operation of the product against any defect of manufacture and/or vice of material, by the term of (12) months, counted as of the date of purchase on the part of the user, committing itself to repair or to change, to its election, without position some, any piece or component that will fail in normal conditions of use within the mentioned period. This guarantee is valid if the original buyer will have to present /display this certificate properly sealed and signed by the selling house, accompanied by the corresponding invoice of purchase where it consisted the model and serial number of the acquired equipment.

The guarantee does not cover:

- Damages caused by the illegal use of the product, repair and/or nonauthorized modification conducted by people by **T.MIX**.
- Damages caused by the connection of the equipment to other equipment different from the specified ones in the manual of use, or by bad connection to these last ones.
- Damages caused by electrical storms, blows and / or incorrect transport.
- Damages caused by excesses or falls of tension in the network or by connection to networks with a tension different from the required one by the unit.
- Damages caused by the presence of sand, acid of batteries, water, or any strange element inside the equipment.
- Deteriorations produced by the course of the time, use and/or normal wear of the unit.
- Alteration or absence of the serial number of factory of the equipment.

The repairs could only be carried out the authorized technical service by **T.MIX**, that will inform about the term and other details into the repairs to take place according to this guarantee.

**T.MIX**, will repair this unit in counted a term nongreater to 30 days as of the date of entrance of the unit to the Technical Service. In those cases in that due to the particularity of the spare part, outside necessary their import, the repair time and the viability of the same one will be subject to the effective norms for the import of parts, in which case one will inquire to the user about the term and possibility into repair.

With the object of its correct operation, and of the validity of this one guarantee, this product will have to be installed and to be used according to the instructions that are detailed in the manual associate or the package of the product.

This unit will be able to appear for its repair, next to the invoice of purchase (or any other comprobante where the date of purchase consists), to its authorized distributor **T.MIX** or an authorized technical center on watch by **T.MIX**.

**Exclusion of damages:**

THE RESPONSIBILITY OF TOPP PRO BY ANY DEFECTIVE PRODUCT IS LIMITED THE REPAIR OR THE REPLACEMENT OF HE HIMSELF, TO TOPP OPTION PRO. IF WE CHOSE TO REPLACE THE PRODUCT, THE REPLACEMENT CAN BE A RECONDITIONATED UNIT. TOPP PRO WILL NOT BE RESPONSIBLE BY THE DAMAGES BASED ON THE LOST, INCONVENIENCE, LOSS OF USE, BENEFITS, LOST SAVINGS, BY THE DAMAGE TO OTHER EQUIPMENT OR OTHER ARTICLES IN THE USE SITE, OR BY ANY OTHER DAMAGE IF HE IS FORTUITOUS, CONSEQUENT OR OF ANOTHER TYPE, ALTHOUGH TOPP PRO HAS BEEN NOTICED OF THE POSSIBILITY OF SUCH DAMAGES.

Some states do not allow to exclusion or the limitation to the fortuitous or consequent damages, so the aforesaid limitation can not be applied to you.

This guarantee gives specific legal rights him, you can also have other right that varies of state to state.

## TABLE OF CONTENTS

---

1. INTRODUCTION.....	1
2. FEATURES.....	1
3. USEFUL DATA.....	1
4. CONTROL ELEMENTS.....	3
5. INSTALLATION TIPS .....	8
6. WIRE CONNECTIONS.....	9
7. BLOCK DIAGRAM .....	10
8. TECHNICAL SPECIFICATION.....	14
9. GUARANTEE .....	15
10. NOTE .....	16

# 1

## INTRODUCTION

Thank you for purchasing the MIX series mixing console. This series include four mixers (MIX 502/MIX 802/MIX 1202). There is 2-band EQ on all mono channels (MIX 502), and 3-band EQ on mono channels and stereo channels (MIX 802/MIX1202). These mixers are really ideal for small club gigs.

Please read this manual carefully so you can take advantages of all the features of the MIX series. Thank you again for making the right choice in purchasing the T.MIX MUSIC GEAR.

# 2

## FEATURES

### MIX 502

- 1 mono inputs with gold plated XLR and Balanced TRS jack
- 2 stereo inputs with Balanced TRS jack
- 2-band EQ on all mono channels
- 2-Track IN/OUT
- Balanced XLR & TRS jack output

### MIX 802/MIX 1202

- 2 mono inputs (4 for MIX 1202) with gold plated XLR and Balanced TRS jack
- 4 (2 for MIX 802) stereo inputs with Balanced TRS jack
- GAIN control and +48V phantom power for mono inputs
- 3-band EQ on all mono channels and stereo channels  
3-band EQ (plus 75Hz low cut filter) on all mono channels (For MIX 1202)
- 1 POST-fader AUX send for effect sends can be changed in PRE-fader for monitoring
- Peak LED in each channel
- 2-Track IN/OUT with discrete switches for routing to Control Room and to Main Mix

# 3

## USEFUL DATA

Please write your serial number here for future reference.

Serial Number:

Data of Purchase:

Purchased at:

# 8

## TECHNICAL SPECIFICATION

Model Number	MIX Series Mixer	
Frequency Response	Mic Input to any Output (Trim at 0 dB)	
	+0, -1 dB	10 Hz to 150 kHz
	-3 dB	10 Hz to 200 kHz
Distortion	THD and SMPTE IMD	20 Hz to 20 kHz
	Mic Input to Main Output	<0.005% @+4 dBu output
Noise	20 Hz to 20 kHz BW (150 Ohm source impedance)	
	Equivalent Input Noise (EIN)	-129 dBu
	Residual Output Noise	
CMRR	Main, Ctrl Room, Phones	-106 dBu
	Mic In	60 dB@1 kHz, Gain@ aximum
Crosstalk	Adjacent Inputs or Input to Output	-90 dB@1 kHz
	Input Gain Control Range	0 dB to 50 dB
Equalization	Phantom Power	+48 VDC
	High	+/-15 dB@12 kHz
	Mid (except for MIX 502)	+/-12 dB@2.5 kHz
	Low	+/-15 dB@80 Hz
Mixer Rated Output	Main, Aux, Control Room	+4 dBu
	Maximum Rated Output	+22 dBu
Maximum Input Levels	Mic Input	+12 dBu, Gain @+10 dB
	Line Input	+30 dBu, Gain @+10 dB
	Tape Input and Aux Return	+22 dBu
Input Impedance	Mic Input	2.6 kΩ, balanced
	Line Input	20 kΩ, balanced
	Stereo Aux Returns	20 kΩ, balanced
	CD/Tape In	24 kΩ, unbalanced
	Phones Output	25 Ω
Output Impedance	Main	240 Ω, balanced; 120 Ω, unbalanced
	Ctrl Room, Aux Sends	120 Ω
	Tape Output	1 kΩ
	Phones Output	25 Ω
	VU Meters	Main Left and Right (4-segment)
AC Power Requirements	External Power Supply Ourput	18.5 VACx2@150 mA (3-pin AC power connection)
	External Power Supply AC Input	
	U.S.	120 VAC, 60 Hz
	Europe	240 VAC, 50 Hz
	Japan	100 VAC, 50/60 Hz
Physical	Korea	220 VAC, 60 Hz
	Dimensions (H x W x D)	
	MIX 502	41 x 133 x 203 mm (1.6" x 5.2" x 8.0")
	MIX 802	203 x 133 x 41 mm (8.0" x 5.2" x 1.6")
	MIX 1202	41 x 272 x 259 mm (1.6" x 10.7" x 10.2")
	Net Weight	
	MIX 502/MIX 802	0.7 Kg (1.6 lb)/1.2 Kg (2.7 lb)
MIX 1202	1.4 Kg (3.1 lb)/1.8 Kg (3.9 lb)	

BLOCK DIAGRAM

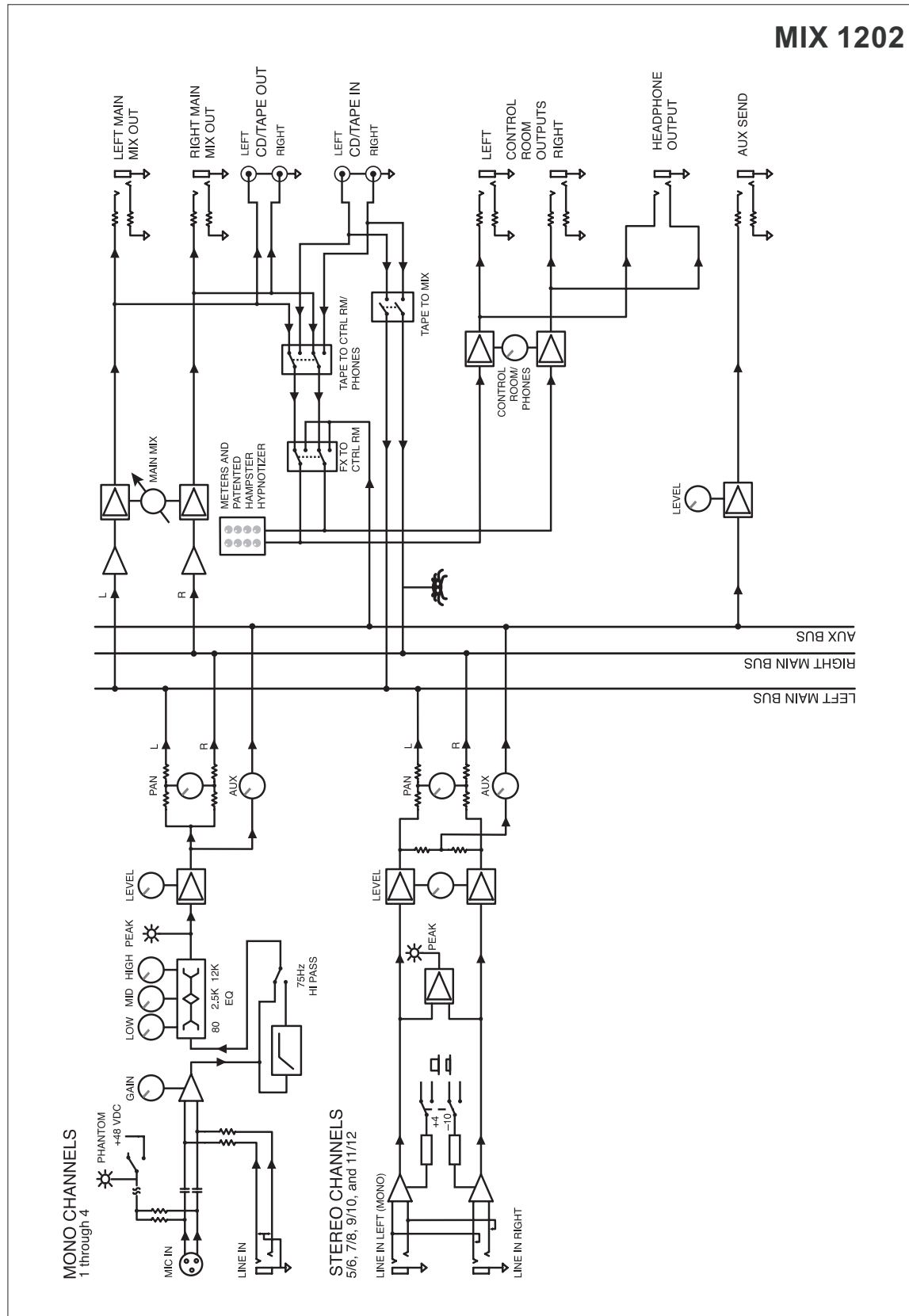

HOOKUP DIAGRAM

Small Club Gig

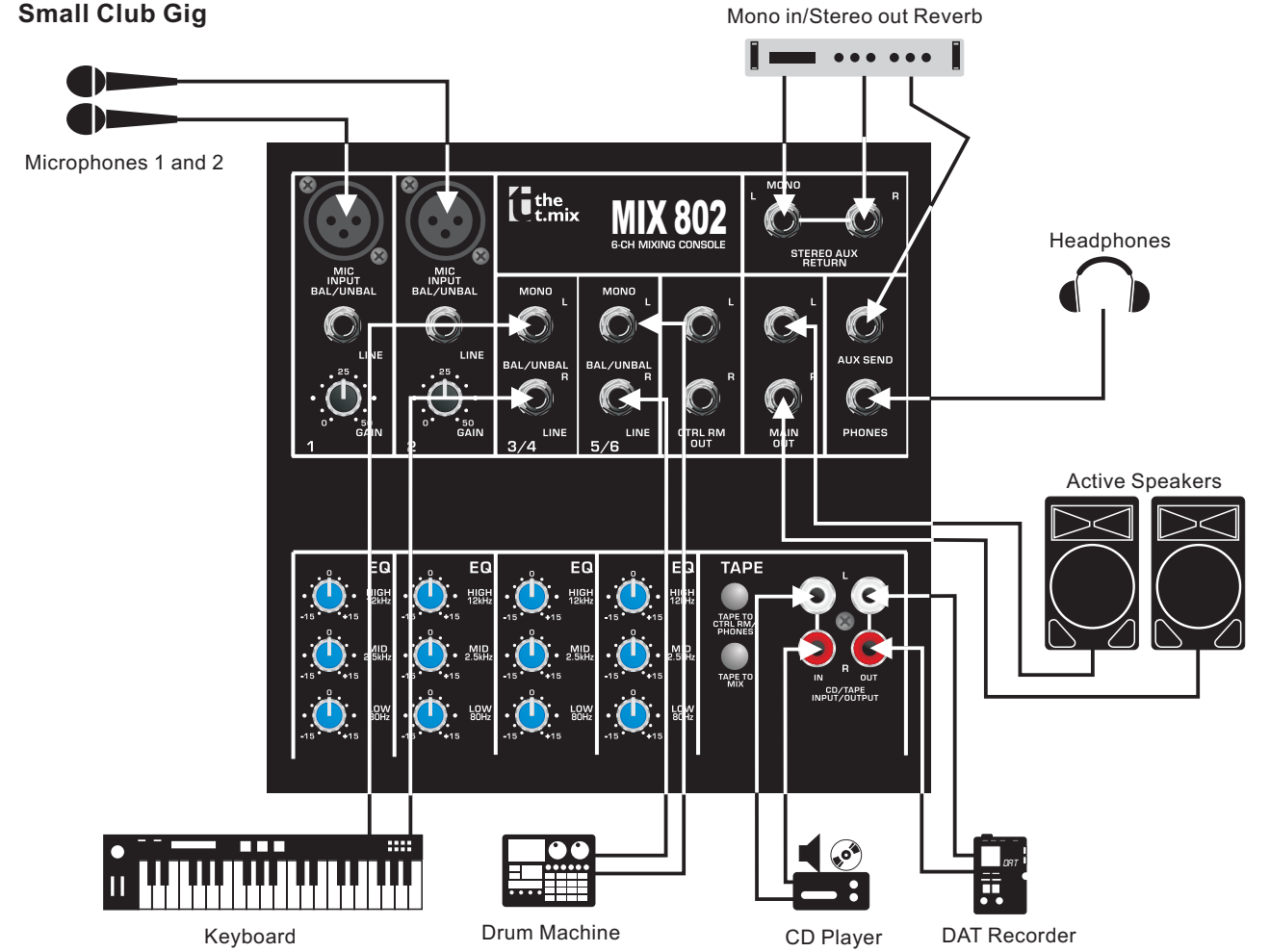

Computer Set-up

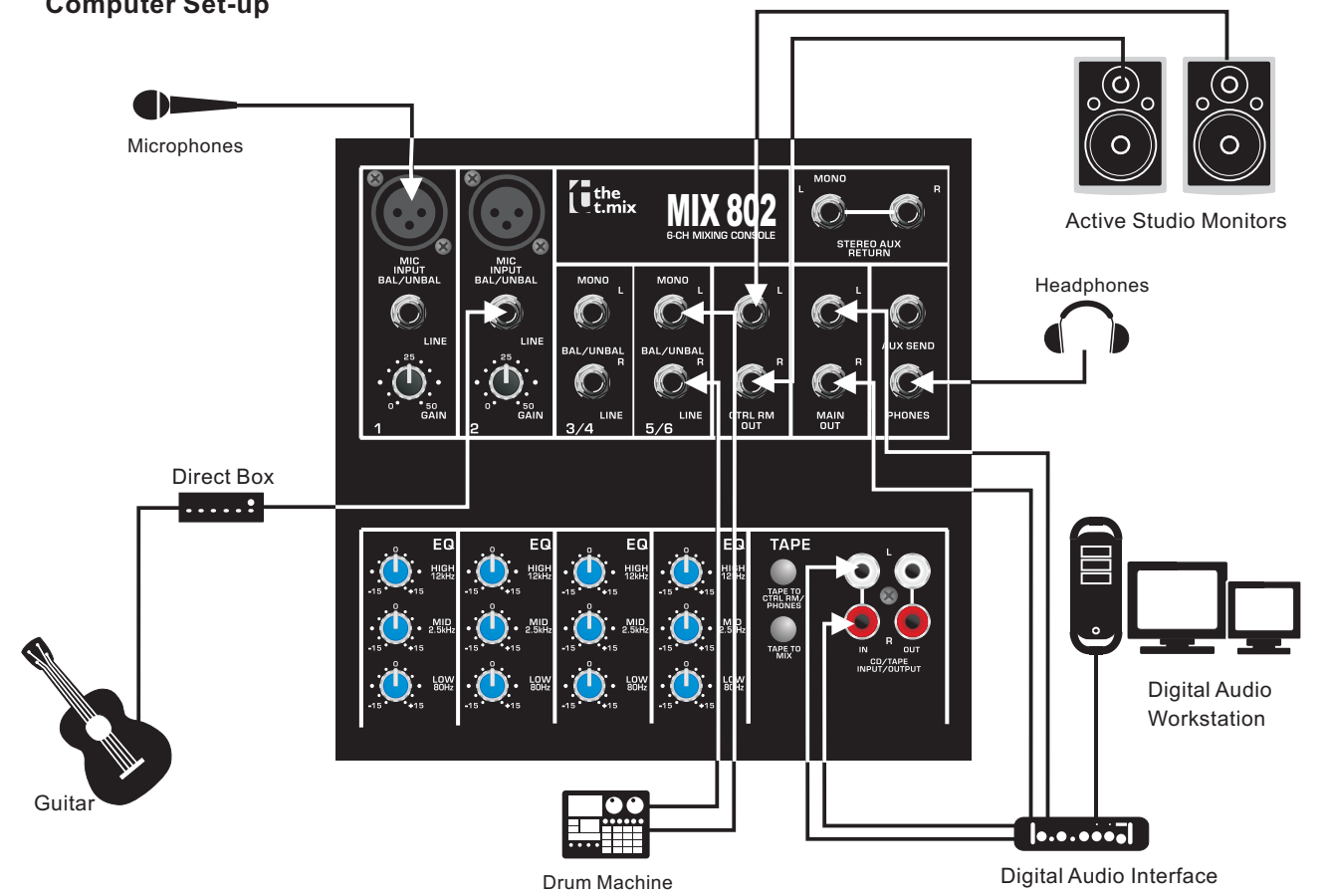

# 4

## CONTROL ELEMENTS

### Mono MIC Input 1

The MIX series is equipped with one or more low-noise microphone preamplifiers with optional phantom power providing up to 50dB of amplification. You can connect almost any type of microphone. Dynamic microphones do not need phantom power. Use phantom power only with condenser microphones but make sure that the phantom power switch is disengaged before connecting the microphone. Phantom power will not damage your dynamic microphones but it may damage tube or ribbon microphones so make sure to read the microphone instructions manual before engaging phantom power switch. There are also equipped with 1/4" TRS balanced and TS unbalanced LINE IN plug, you can connect with line-level instruments, such as synthesizers, keyboards, drum machines or effect devices.

**NOTE:** Never try to connect a line-level signal to the XLR MIC input when the phantom power is engaged, doing this you may seriously damage your equipment.



### LINE INPUTS 2

They are organized in stereo pair and provided with 1/4" TRS sockets. It is used to connect the stereo device, plug both the left input and the right input. Using the left input if connect a mono input signal to the STEREO INPUT, the signal will appear on both sides.

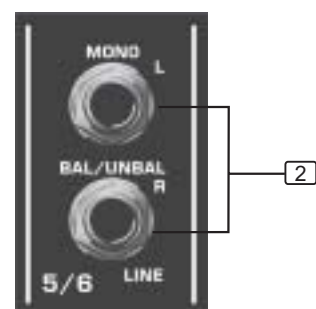

### GAIN CONTROL 3

This GAIN control is used to control the input sensitivity of the MIC and LINE inputs. The adjustable range goes from 0 dB to 50dB.

### EQUALIZATION

The MIX series has 3-band EQ on all mono channels (except MIX 502 has 2-band EQ). And only the MIX 802 has EQ controls on stereo channels. All bands provide up to 15 dB boost or cut.

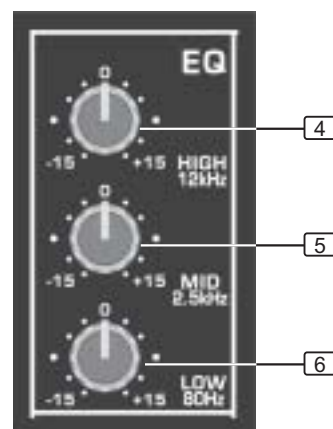

## BLOCK DIAGRAM

# 7

7

BLOCK DIAGRAM

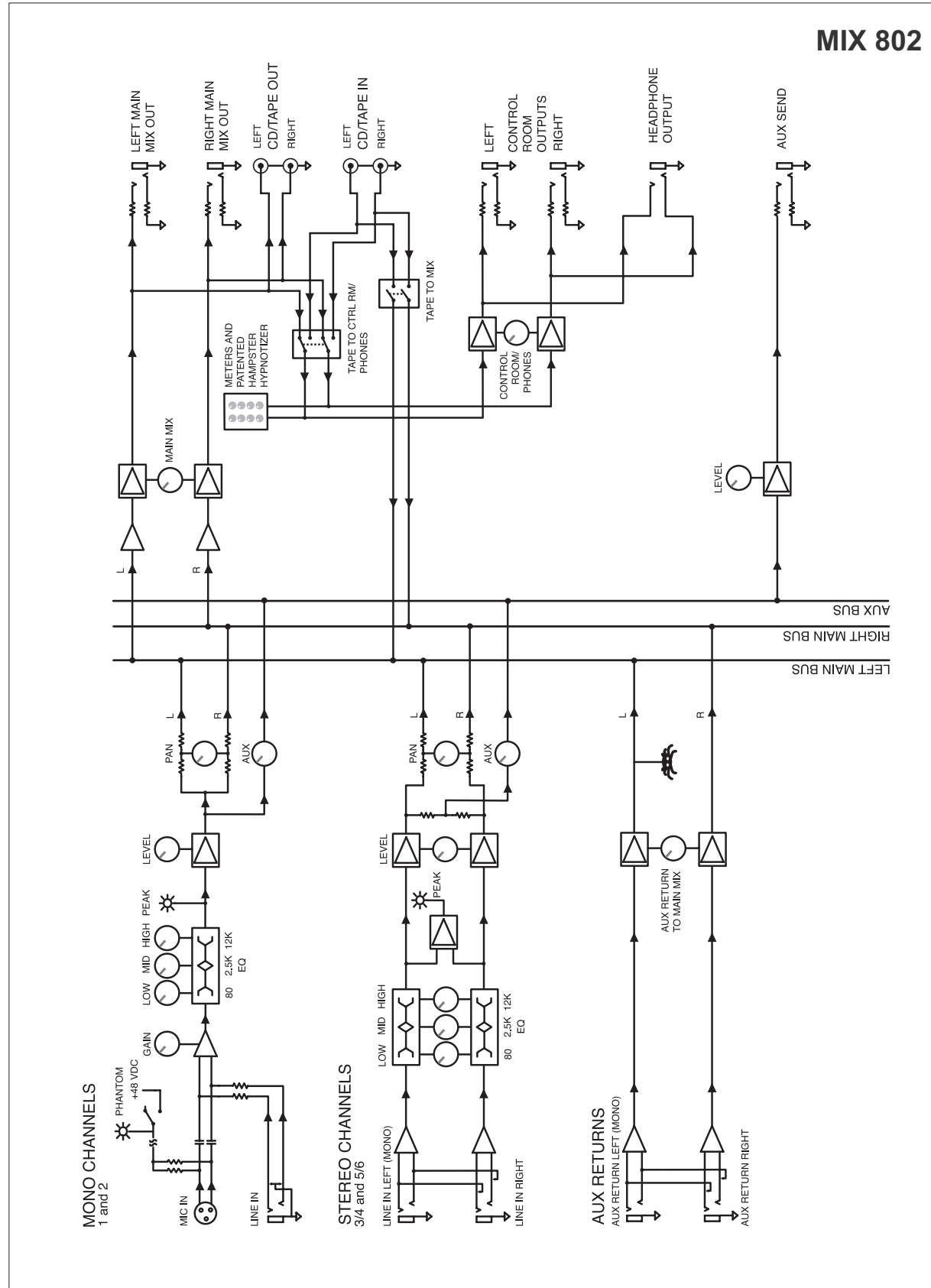

4

CONTROL ELEMENTS

**HIGH** 4

This is the treble control. You can use it to get rid of high frequency of the human voice. The gain range goes from -15 dB to +15 dB with a centre frequency of 12 kHz.

**MID EQ (except MIX 502)** 5

This control provides 15 dB boost or cut at 2.5 kHz. It can affect most fundamental frequencies of all musical instruments and human voice.

**LOW EQ** 6

This is the bass control. It is used to boost male voice, kick-drum or bass guitar. Your system will sound much bigger than what it is. The gain range goes from -15 dB to +15 dB and the center frequency is 80 Hz.

**75 Hz Low-Cut Switch (MIX 1202 only)** 7

By pressing this button you will activate a 75Hz low frequency filter that cuts the bass frequency below 75Hz. You can use this switch to reduce the hum noise caused by the mains power supply, or the stage rumble while using a microphone.

**+4/-10 Switch (MX 1202 only)** 8

These switches are used to select the input sensitivity of the line inputs on the stereo channels. +4 dBu is suitable for professional audio devices and -10 dBv is suitable for general devices. If not sure to use which setting, try +4 dBu first, then change it to -10 dBv if the volume is too small to be satisfied.

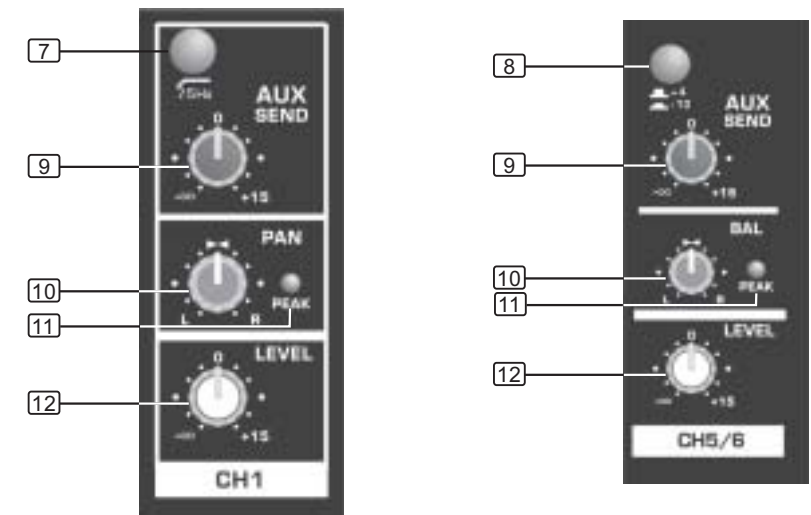

**AUX Send (except MIX 502)** 9

This control is used to feed the mono input of parallel effects devices or the input of a stage monitor amplifier via the AUX SEND output jack. All the channel controls (except PAN or BAL) will affect the AUX signal. The signal is tapped off after the LEVEL control. The output from an external processor can come back via the STEREO AUX RETURN inputs (on the MIX 802) or stereo channel (MIX 1202), and be added to the main mix.

CONTROL ELEMENTS

PAN/BAL 10

Abbreviation of PANORAMA control for mono channels, for the stereo channels, always says, BALANCE control. You can adjust the stereo image of the signal via this control. For mono MIC/LINE channels, keep PAN control in centre position and your signal will be positioned in the middle of stage that is to say the mono signal appears equally in both sides. Turn this control fully counterclockwise and the signal will be present only on the left speaker and vice-versa. For stereo channels, by rotating the BAL control, you can attenuate the signal of left or right. It means if turn the control to left, the right channel will be attenuated; if turned to right, the left channel will be attenuated.

PEAK LED 11

When this LED blinks, it warns you that you are reaching signal saturation and possible distortion. From this LED you can adjust the correct level, not too strong to cause distortion and not too weak to be lost in noise.

LEVEL 12

This control will adjust the overall level of this channel. If you set the LEVEL control in max, it's usually a sign that your GAIN is set too low. If set the LEVEL control in min, your GAIN may be too high.

CD/TAPE INPUTS 13

Use the Tape Input if you wish to listen to your mixer from a Taper Recorder or DAT. When the TAPE TO MIX switch is pushed in, the signal coming from Taper Recorder will assign to main mix; when the CD/TAPE switch which on the front panel is engaged in the signal can also be assigned to the CONTROL ROOM/PHONES outputs. If you connect a mono device, you will need a "Y-splitter" RCA adapter.

TAPE OUTPUTS 14

These RCA jacks will assign the main out signal to a tape recorder or DAT. The TAPE OUT level is affected by MAIN MIX control.

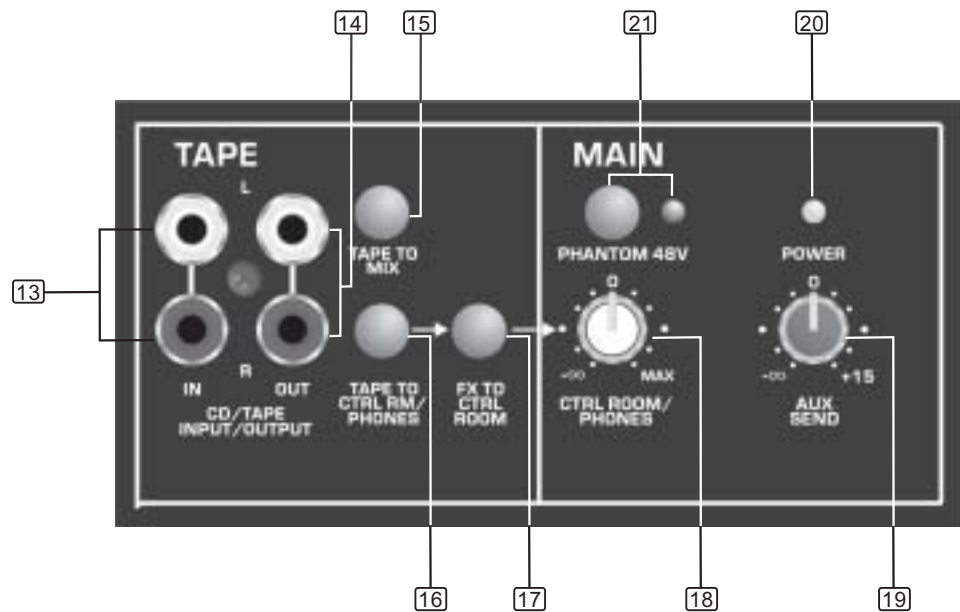

BLOCK DIAGRAM

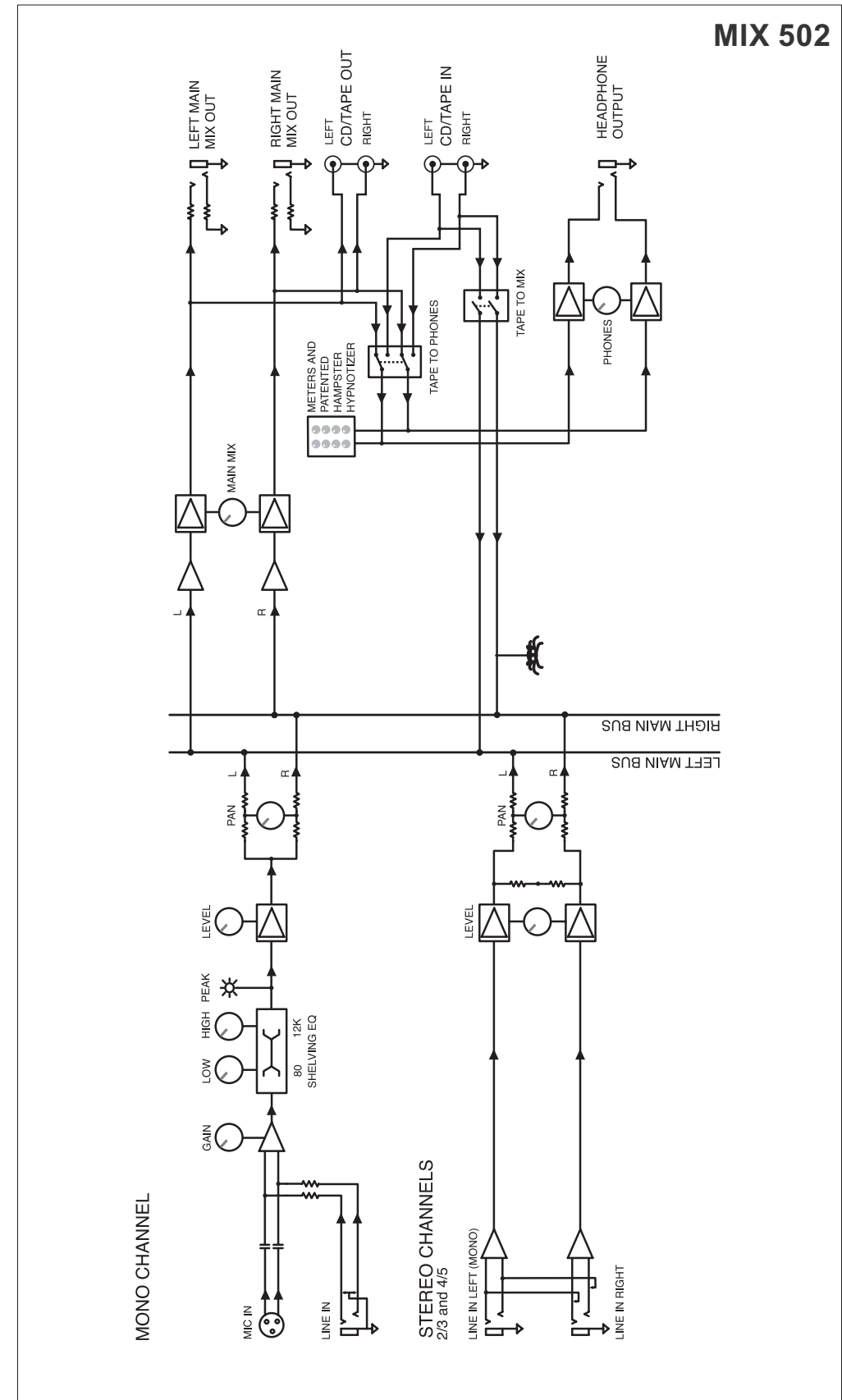



# 6

## WIRE CONNECTIONS

Either the 1/4" TRS phone jack or XLR connector can be wired in balanced and unbalanced modes, which will be determined by the actual application status, please wire your system as the following wiring examples:

- For 1/4" Phone jack

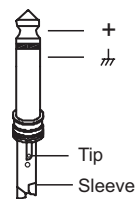

TS Type Unbalanced

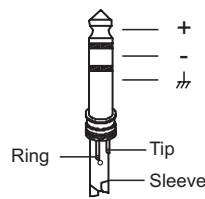

TRS Type Balanced

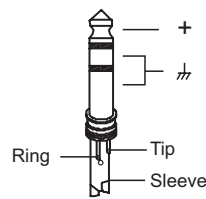

TRS Type Unbalanced

- For XLR Connector

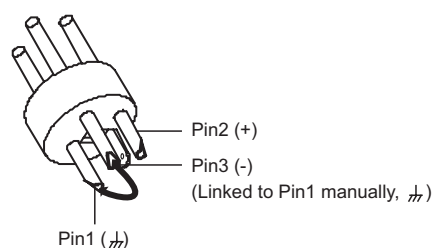

XLR Type Unbalanced

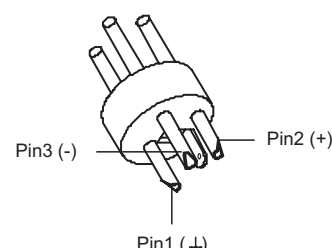

XLR Type Balanced

### In-line Connection

For these applications the unit provides 1/4" TRS and XLR connectors to easily interface with most professional audio devices. Follow the configuration examples below for your particular connection.

- Balanced

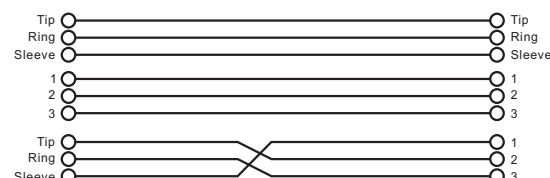
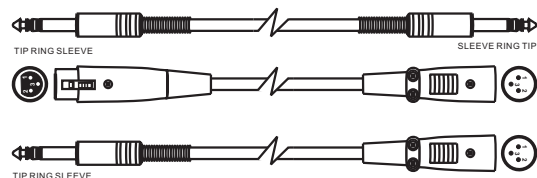

- Unbalanced

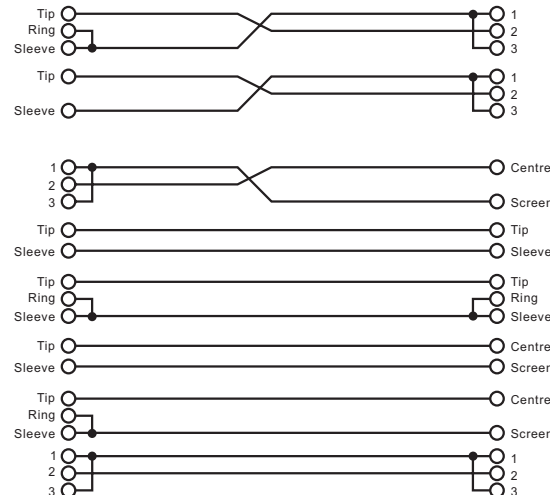
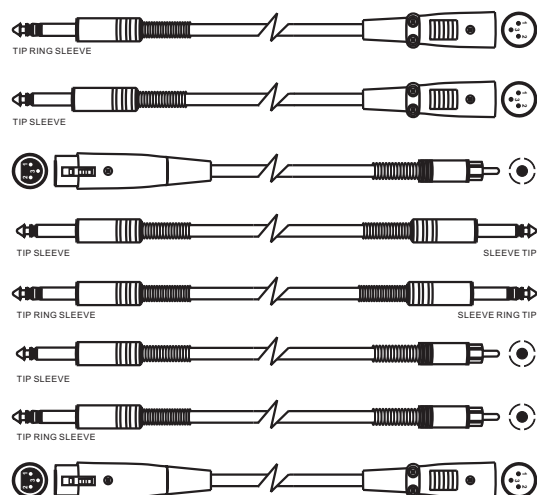

# 4

## CONTROL ELEMENTS

### TAPE TO MIX Switch 15

Connect a CD or Tape Deck to the CD/TAPE inputs, and push down this switch to add the CD/TAPE signal to the main mix. The volume level is controlled by MAIN MIX control.

### TAPE TO CTRL RM/PHONES Switch (TAPE TO PHONES on MIX 502) 16

Switch is used to select the signal source for the CONTROL ROOM outputs, PHONES, and METERS. Release this switch, they all receive the main mix signal tapped after the MAIN MIX control. Engage this switch, they all receive the CD/TAPE Input signal. Turn down the CTRL ROOM/PHONES control (just PHONES on the MIX 502) before engaging.

### FX TO CTRL ROOM Switch (MIX 1202 only) 17

Engage this switch to monitor the aux send signal in the Control Room/Phones outputs.

### CTRL ROOM/PHONES Control (PHONES control on the MIX 502) 18

This control is used to adjust the signal level going to the CONTROL ROOM/PHONES outputs. And it won't affect the Main Mix output.

### MASTER AUX SEND Control (except MIX 502) 19

This knob is used to determine the master AUX SEND levels. The adjustable range is from  $-\infty$  to +15 dB. When the external effect unit connected to mixer has no input gain control, you can get a further +15 dB gain available from these AUX SEND outputs.

### POWER LED 20

This LED lights up when the power switch is turned on.

### PHANTOM 48V Switch and LED 21

This +48VDC Phantom Power switch only apply to the XLR microphone inputs. Never connect microphones when the phantom power is on already. The LED near to this switch will light up when the phantom power is switched on.

**NOTE:** Turn down all output levels before operating this switch to avoid the possibility of "pop" in your speakers. Do not use phantom power with tube or ribbon microphones, as this may cause damage.

### METERS 22

This stereo LED meter will indicate the level of the overall output signal.

### MAIN MIX 23

This control sets the level of main mix signals sent to the Main Outputs, Tape Outputs, CONTROL ROOM, PHONES, and LED Display. On the MIX 502 and MIX 802, this is a rotary control; on the MIX 1202, this is a fader.

**Note:** When connecting a speaker to the speaker output jacks, please pay more attention to the level setting for avoiding damaging the speaker. Generally speaking, the faders will be positioned between 0 dB and the +5 dB.

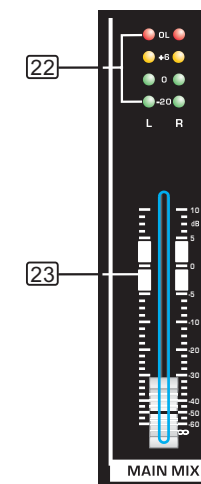

# 4

## CONTROL ELEMENTS

### MAIN OUT 24

These 1/4" TRS jacks represent the end of the mixer chain, where your fully mixed stereo signal enters the real world. Connect these outputs to the inputs of your amplifiers, powered speakers, or serial effects processor (graphic equalizer, for example).

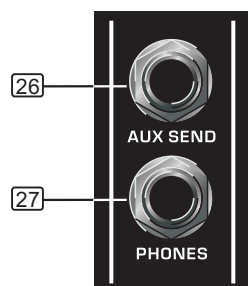
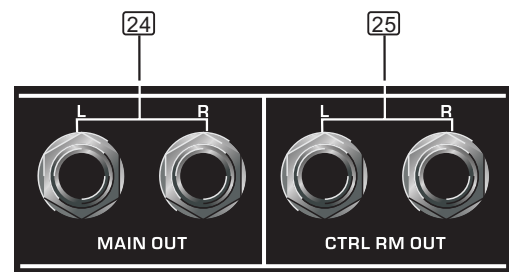

### CTRL ROOM OUT 25

These 1/4" TRS are used to assign the control room signal to the studio monitor speakers. They can also be used to provide another main mix output, or to monitor the CD/TAPE Inputs (when engage the TAPE TO CTRL RM/PHONES switch), or to monitor the aux send signal (MIX 1202 only with FX TO CTRL ROOM switch is engaged)

### AUX SEND OUT 26

These 1/4" TRS are used to send out the signal from the AUX bus to external device such as effects equipment. Each channel has an AUX SEND control knob that adjusts how much of that channel's signal appear at each of the output. This output is affected by the channel LEVEL, but not MAIN MIX control.

### PHONES OUTPUT 27

This jack is used to send out the mix signal to a pair of headphones, and the signal is the same as the CTRL RM OUTS outputs. The level is controlled by the CTRL ROOM/PHONES knob. You can listen to the Main Mix, the CD/TAPE, or the AUX SEND (MIX 1202) depending upon the position of the TAPE TO CTRL RM/PHONES switch and FX TO CTRL ROOM switch.

### Rear Panel



### POWER IN 28

This connection is where you connect the supplied external AC power supply to provide AC power to the mixer. Connect the external power supply to your mixer first, then plug the power supply into a suitable and properly rated AC outlet.

**NOTE:** Make sure you use the correct external power supply cable of providing 18.5 VACx2 at milliamps.

# 5

## INSTALLATION TIPS

- 1- Speakers should be placed in a position that allows for unobstructed sound projection. In many instances it is beneficial for speakers to be elevated on tripod stands to achieve maximum dispersion and reach.
- 2- Use professional advice or service when hanging and installing speakers. Please take precautions to secure them to prevent them from falling and hurting someone. Care should be taken as to not damage the cabinet or its components. Please comply with all pertinent Regulations.
- 3- Use quality cables. Using quality cables will ensure the best possible sound.
- 4- For best results match the speakers to a good amplifier that matches the wattage and impedance of your speakers. Proper amplification power results in good quality audio and longer component life. Check out the power requirement for your cabinet.
- 5- Avoid pointing a microphone directly at an amplified speaker doing so, could cause feedback possibly damaging speaker components and your hearing.

**Enjoy the sound!**